



# Results for the 1st half of the fiscal year ending March 31, 2022

1. This fiscal year results cover period from April to September 2021 of Ferrotec, and period from January to June 2021 of consolidated subsidiaries and companies accounted for using the equity method.
2. This presentation was prepared for the purpose of providing information regarding the company's results of operations for the first half of the fiscal year ending March 31, 2022 and is not a solicitation to purchase securities issued by the company. Please ensure that the decision on whether to make an investment in our company is made at your own risk.
3. These materials were prepared based on information available as of date of the disclosure. All opinions, forecasts and other forward-looking statements are based on management's judgments in accordance with materials available at that time and may be changed without prior notice.

# Consolidated Financial Summary

(Million yen)	Q2 FY3/21	Q2 FY3/22	YoY	
	Amount	Amount	Amount	Pct. change (%)
Net sales	41,595	59,826	18,231	43.8
Cost of sales	27,497	37,588	10,091	36.7
Gross income	14,099	22,239	8,140	57.7
SG&A expenses	10,185	11,505	1,320	13.0
Operating income	3,913	10,733	6,820	174.3
Non-operating income	1,053	2,284	1,231	116.8
Non-operating expenses	2,142	524	-1,618	-75.5
Ordinary income	2,825	12,493	9,668	342.3
Extraordinary income	-	9,340	9,340	-
Extraordinary loss	1,079	1,162	83	7.7
Net income attributable to non-controlling shareholders	118	345	227	192.8
Net income attributable to owners of parent	71	17,269	17,198	242.5
Capital investment	10,136	13,899	3,763	37.1
Depreciation	4,605	3,771	- 834	- 18.1

Net sales: 59.8 billion yen, +44% YoY

Operating income: 10.7 billion yen, +174% YoY

Net income: 17.3 billion yen, +243% YoY

•SG&A expenses

Up 13% YoY due to increase in labor cost and R&D expenses

•Non-operating income

Foreign exchange gains: 1,503 million yen

•Non-operating expenses

Equity in losses of affiliates (net): 15 million yen (including 3 wafer businesses: 503 million yen)

Extraordinary income

•Gain on change in equity: 9,327 million yen (Third-party allotment of new shares in wafer business: 3.3 billion yuan, 3 yuan/share)

Extraordinary loss

•Loss on withdrawal from business, withdrawal from FTAK (Korea) business: 927 million yen

Net income attributable to non-controlling interests (net of tax)

•Cleaning business: 239 million yen  
•Wafer recycling: -183 million yen

Note: Exchange rate FY3/21⇒FY3/22: US\$ \108.24 → ¥108.45; RMB \15.32 → \16.76 (Avg. during period)

# Sales and Operating Income by Segment

Net sales (¥ in millions)	Q2 FY3/21		Q2 FY3/22		YoY	
	Amount	Pct. of sales (%)	Amount	Pct. of sales (%)	Difference	Pct. change (%)
Semiconductor and other equipment-related	28,785	69.2	35,895	60.0	7,110	24.7
Electronic device	7,116	17.1	12,214	20.4	5,097	71.6
Others	5,694	13.7	11,718	19.6	6,024	105.8
<b>Total</b>	<b>41,595</b>	<b>100.0</b>	<b>59,826</b>	<b>100.0</b>	<b>18,231</b>	<b>43.8</b>

Operating income (¥ in millions)	Q2 FY3/21		Q2 FY3/22		YoY	
	Amount	Profit margin (%)	Amount	Profit margin (%)	Difference	Pct. change (%)
Semiconductor and other equipment-related	2,177	7.6	7,104	19.8	4,927	226.3
Electronic device	1,868	26.2	3,053	25.0	1,185	63.4
Others	345	6.1	700	6.0	355	103.1
Corporate & elimination	-477	-	-124	-	353	-
<b>Total</b>	<b>3,913</b>	<b>9.4</b>	<b>10,733</b>	<b>17.9</b>	<b>6,820</b>	<b>174.3</b>

# Sales by Product

(Million yen)	Q2 FY3/21	Q2 FY3/22	YoY Pct. change
Semiconductor and other equipment-related	28,785	35,895	24.7
Vacuum feedthroughs	4,377	6,018	37.5
Quartz	7,713	10,132	31.4
Silicon parts	1,411	2,778	96.9
Ceramics	5,681	8,422	48.2
CVD-SiC	1,143	1,389	21.5
EB-Gun, LED	1,450	2,056	41.8
Wafer recycling	-	-	-
Wafer processing	3,102	43	-98.8
Equipment parts cleaning	3,458	4,483	29.6
Quartz crucibles	450	574	27.7
Electronic device	7,116	12,214	71.6
Thermo-electric module	5,501	8,424	53.1
Power semiconductor substrates	1,313	3,349	155.1
Ferrofluid, others	302	440	45.8
Others	5,693	11,718	105.8
<b>Total</b>	<b>41,595</b>	<b>59,826</b>	<b>43.8</b>

## Transition of sales

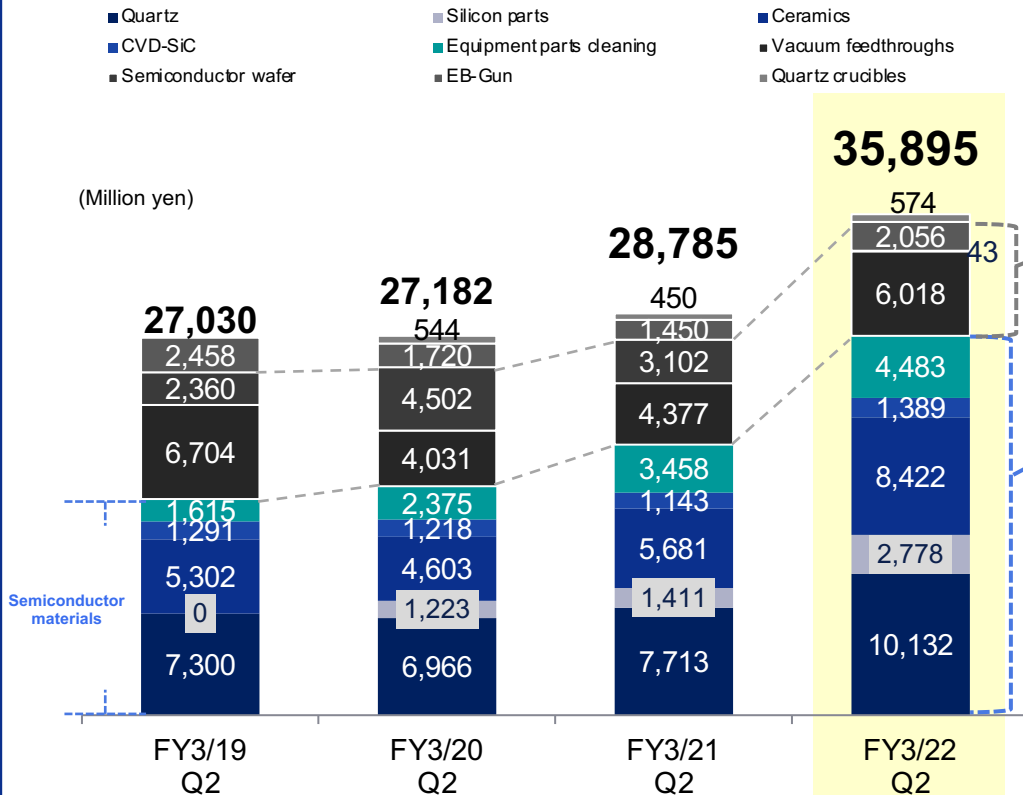

## Overview of this segment

- Increase in sales of vacuum feedthroughs and semiconductor materials
- Offsetting the decline in sales due to the deconsolidation of wafer processing.

### Vacuum feedthroughs, Wafer processing, Wafer recycling

Sales of vacuum feedthroughs increased thanks to a growing demand for vacuum feedthroughs for semiconductor manufacturing equipment, as well as an increase in orders for contract metal processing by semiconductor manufacturing equipment manufacturers.

### Semiconductor materials, Cleaning business

[Semiconductor materials (quartz, silicon parts, ceramics, and CVD-SiC)]

- Quartz: Sales increased due to increased demand and the start of operations at the Changshan and Dongtai plants
- Silicon parts: Sales increased due to increased production capacity at Yinchuan plant in response to increased demand
- Ceramics: Sales increased due to increased demand for products for semiconductors and probe cards
- CVD-SiC: Comment

[Cleaning Business]

- Demand from semiconductor and FPD manufacturers in China is strong, and sales continued to increase.

\*Silicon parts business were previously included in quartz products, but they are separately presented from FY3/20.

## Transition of sales

■ Thermo-electric module ■ Power semiconductor substrates ■ Ferrofluid, others

(Million yen)

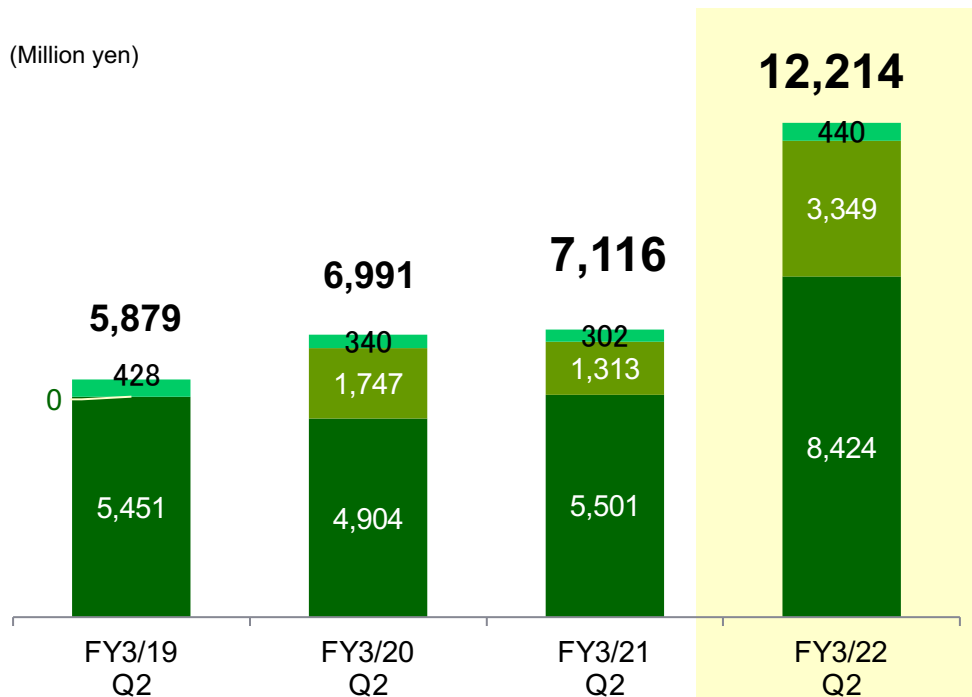

## Overview of this segment

**Sales of thermoelectric modules and power semiconductor substrates both increased.**

### [Thermo-electric module]

- Sales of thermoelectric modules and power semiconductor substrates increased due to strong demand for 5G communication devices and medical applications such as PCR testing machines, as well as increased demand for consumer electronics and consumer products due to increased production capacity at the Changshan plant.

### [Power semiconductor substrates]

- Expanding demand for DCB substrates and expanding production capacity at Dongtai plant contributed to sales growth.
- Demand for AMB substrates for automobiles was also strong, and sales is increasing rapidly thanks to the expansion of production capacity.

# Consolidated Balance Sheet –Assets-

(Million yen)	End-FY3/21	End-FY3/22	Difference
Current assets	88,078	116,255	28,177
Cash & deposits	30,203	48,210	18,007
Note & accounts receivable	32,201	—	-32,201
Notes and accounts receivable - trade, and contract assets	—	37,755	37,755
Inventory	17,126	21,798	4,672
Fixed assets	89,112	111,151	22,039
Tangible fixed assets	53,043	66,696	13,653
Buildings and structures	15,447	16,846	1,399
Equipment and machinery	14,964	17,404	2,440
Tools, furniture, and fixture	4,693	4,741	48
Land	1,894	1,896	2
Leased assets (net)	3,324	3,730	406
Construction in progress	12,721	22,079	9,358
Intangible fixed assets	1,814	1,796	- 18
Goodwill	576	518	- 59
Investments & other assets	34,255	42,659	8,405
Total assets	177,190	227,406	50,216

## [Major factors for increase in current assets]

- Of the 48,210 million yen in cash and cash equivalents, the balance of cash and cash equivalents of the Chinese subsidiary\* that implemented a third-party allotment of new shares: 23,539 million yen

\*FTSJ (DCB), AQM-N (silicon parts, crucibles), FTASM (semiconductor wafer)

## [Major factors for decrease in tangible fixed assets]

- Construction in progress of 22,079 million yen is mainly for capital investment in semiconductor wafer, Yinchuan silicon parts/crucible business, and Dongtai quartz subsidiary in China.

## [Major factors for increase in investments and other assets]

- Due to the third-party allotment of new shares by a wafer business subsidiary, the balance of stocks of subsidiaries and affiliates increased along with the recording of profit on change in equity.

# Consolidated Balance Sheet -Liabilities and Net Assets-

(Million yen)	End-FY3/21	End-Q2 FY3/22	Difference
Current liabilities	58,890	65,190	6,300
Notes and accounts payable	20,013	21,434	1,421
Short-term debt	5,427	5,769	342
Current portion of long-term borrowings + bonds	11,981	11,375	- 606
Fixed liabilities	40,060	37,335	- 2,725
Bonds	11,464	10,030	- 1,434
Convertible bond-type bonds with share acquisition rights	3,735	2,287	- 1,448
Long-term debt	15,023	13,903	- 1,121
Total liabilities	98,950	102,525	3,575
Net assets	78,240	124,880	46,641
Shareholder's equity	63,409	89,797	26,388
Total accumulated other comprehensive income	3,456	7,781	4,324
Non-controlling interests	11,064	26,824	15,759
Total liabilities & shareholder's equity	177,190	227,406	50,216

## [Major factors for changes in current and fixed liabilities]

\*The parenthesis represents the change from the end of FY3/21

Short-term debt + Current portion of long-term debt and bonds: 17,144 million yen (-264)

Long-term debt + bonds and convertible bonds: 26,220 million yen (-4,003)

Total interest-bearing debt: 4,364 million yen (-4,267)

## [Major factors for changes in net assets]

\*The parenthesis represents the change from the end of FY3/21

- Capital surplus: 36,517 million yen (+8,946)  
-Increased due to allotment of new shares to a third party by a Chinese subsidiary
- Retained earnings: 34,821 million yen (+16,599)
- Foreign currency translation adjustment: 7,781 million yen (+4,324)  
-Increased due to the depreciation of the yen (against the Chinese yuan, etc.)
- Non-controlling interests: 26,824 million yen (+15,759)  
-Increased due to third-party allotment of new shares to Chinese subsidiaries\*.

\*FTSJ (DCB), AQM-N (silicon parts, crucibles), FTASM (semiconductor wafer), etc.

Note: Exchange rate FY3/21⇒FY3/22: US\$ \103.50 → ¥110.58; RMB \15.88 → \17.11 (Avg. during period)



# Consolidated Cash Flow

(Million yen)	Q2 FY3/21	Q2 FY3/22
<b>Cash flow from operating activities</b>	<b>5,530</b>	<b>6,370</b>
Income before income tax	1,745	20,671
Depreciation	4,605	3,771
Foreign exchange loss (gain)	715	- 1,199
Changes in notes & accounts receivable (-: increase)	- 3,853	- 2,737
Changes in inventories (-: increase)	- 2,242	- 3,524
Increase/decrease in notes and accounts payable-trade (-: decrease)	66	1,801
Loss on change in equity (-: gain)	-	- 9,327
Others	4,494	- 3,086
<b>Cash flow from investing activities</b>	<b>- 9,967</b>	<b>- 8,226</b>
Payments for purchase of tangible fixed assets	- 10,108	- 13,814
Proceeds from sales of tangible fixed assets	171	352
Payments for purchase of intangible fixed assets	- 28	- 85
Others	- 1	5,321
<b>Cash flow from financing activities</b>	<b>15,875</b>	<b>18,275</b>
Changes in short-term debt	1,682	115
Proceeds from long-term borrowings	9,488	1,707
Payments of long-term borrowings	- 5,615	- 3,667
Proceeds from share issuance	-	84
Proceeds from share issuance to non-controlling shareholders	696	22,182
Others	9,623	- 2,146
Changes in cash & cash equivalents	11,172	18,007
Cash and cash equivalents, beginning of year	23,709	30,203
Cash and cash equivalents, end of year	34,881	48,210

## [Operating cash flow]

**Income before income tax + Depreciation:  
24,442 million yen**

**Changes in notes & accounts receivable, inventories  
and accounts payable: -4,460 million yen**

## [Investing cash flow]

**Purchase of tangible and intangible fixed assets: -  
13,899 million yen**

## [Financial cash flow]

**Proceeds from payments by noncontrolling interests:  
22,182 million yen**

- AQM-N (crucible, silicon parts): 9,146 million yen
- FTSJ (DCB): 8,307 million yen
- FTASM (Semiconductor wafer): 4,387 million yen



**Ferrotec**  
Ferrotec Holdings Corporation



## Business Forecasts for FY3/22

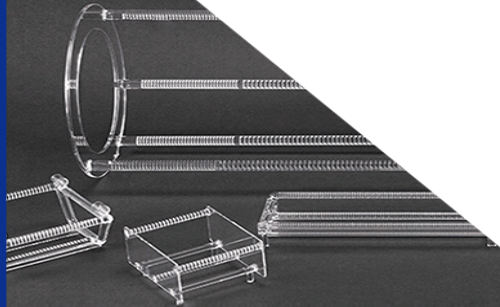

# FY3/22 Full-year Business Forecasts

- Considering strong demand, we announced the second upward revision to the forecast on November 12, after the first upward revision on August 13.
- Sales and operating income are expected to reach new record highs, with significant increases in both sales and profits from the previous fiscal year.

(Million yen)	FY3/21	FY3/22 (Est.)		YoY (%)
		Revised on August 13	Revised on November 12	
Net sales	91,313	115,000	<b>125,000</b>	<b>36.9</b>
Operating income	9,641	20,000	<b>22,500</b>	<b>133.4</b>
Ordinary income	8,228	20,000	<b>23,500</b>	<b>185.6</b>
Net income attributable to owners of parent	8,281	20,000	<b>23,500</b>	<b>183.8</b>
Depreciation	9,155	-	<b>8,000</b>	<b>-12.6</b>
EBITDA	18,796	-	<b>31,500</b>	<b>67.6</b>

Note: Exchange rate FY3/21⇒FY3/22: US\$ \106.43 → ¥109.11; RMB ¥15.42 → ¥16.86 (Avg. during period)

\*EBITDA = operating income + depreciation and amortization; profits and losses from external investments in consolidated subsidiaries are included in non-controlling interests.

# FY3/22 Sales by Product (YoY)

(Million yen)	FY3/21	FY3/22 (Est.)	YoY Pct. change
Semiconductor and other equipment-related	60,669	76,379	25.9
Vacuum feedthroughs	8,795	13,218	50.3
Quartz	17,116	20,332	18.8
Silicon parts	3,226	7,278	125.6
Ceramics	12,267	17,572	43.2
CVD-SiC	2,186	2,949	34.9
EB-Gun, LED	3,872	4,066	5.0
Wafer processing (Note)	4,638	43	-
Wafer recycling	0	4	-
Equipment parts cleaning	7,579	9,483	25.1
Quartz crucibles	990	1,434	44.9
Electronic device	17,273	26,094	51.1
Thermo-electric module	13,036	17,124	31.4
Power semiconductor	3,491	8,049	130.6
Ferrofluid, others	746	920	23.3
Others	13,370	22,528	68.5
<b>Total</b>	<b>91,313</b>	<b>125,000</b>	<b>36.9</b>

Note: Exchange rate FY3/21⇒FY3/22: US\$ \106.43 → ¥109.11; RMB ¥15.42 → ¥16.86 (Avg. during period)

## Transition of sales

- Quartz
- Silicon parts
- Ceramics
- CVD-SiC
- Equipment parts cleaning
- Vacuum feedthroughs
- Wafer processing
- Wafer recycling
- EB-Gun
- Quartz crucibles

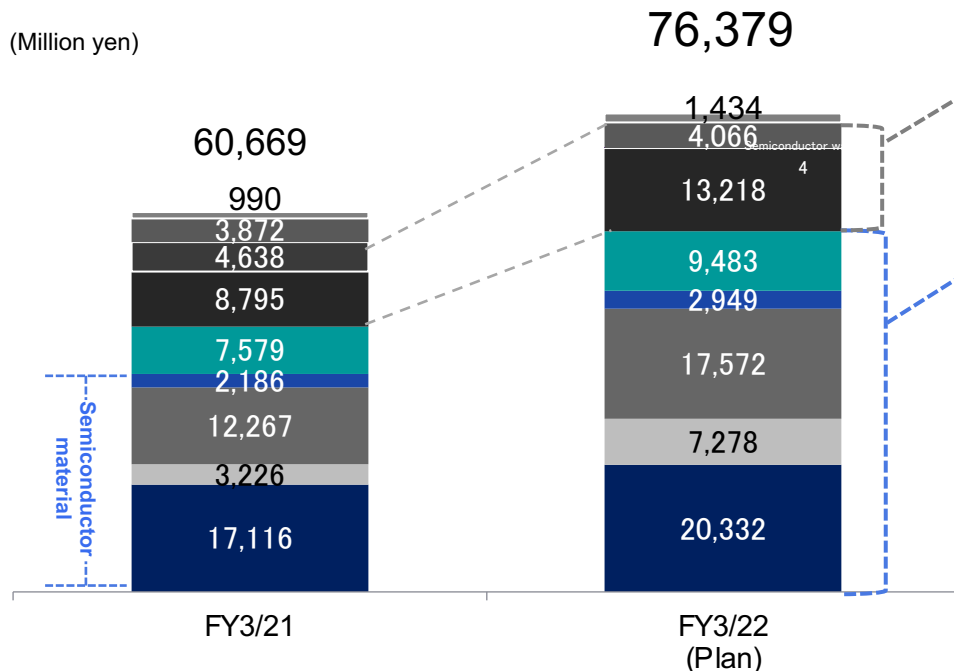

## Overview of this segment

- Sales of semiconductor materials, cleaning, and vacuum feedthroughs are all expected to continue to increase.

## Vacuum feedthroughs

- In addition to expanding demand for vacuum feedthroughs for semiconductor manufacturing equipment, we are aggressively expanding its metal processing business for chambers and robot parts for semiconductor manufacturing equipment, and sales are expected to grow.

## Semiconductor materials, Cleaning business

[Semiconductor Materials (Quartz, Silicon parts, Ceramics, CVD-SiC)]

- Quartz:** Demand for increased production from semiconductor-related manufacturers continued, and sales are expected to increase with the start of operations at the Jyongsan plant and the Dongtai plant.
- Silicon parts:** Demand for silicon parts is growing rapidly, and sales are expected to increase sharply due to the operation of the Yinchuan plant, which has expanded its production system.
- Ceramics:** Demand from semiconductor-related manufacturers is expected to continue to grow, and sales to probe card manufacturers are also expected to be strong.
- CVD-SiC:** Demand from semiconductor-related manufacturers is expanding, and sales are expected to grow.

[Cleaning Business]

- Demand for semiconductor-related cleaning services in China is expanding steadily, and sales growth is expected to continue as we promote to build new plants and expand the service field.

## Transition of sales

■ Thermo-electric module ■ Power semiconductor substrates ■ Ferrofluid, SMT, others

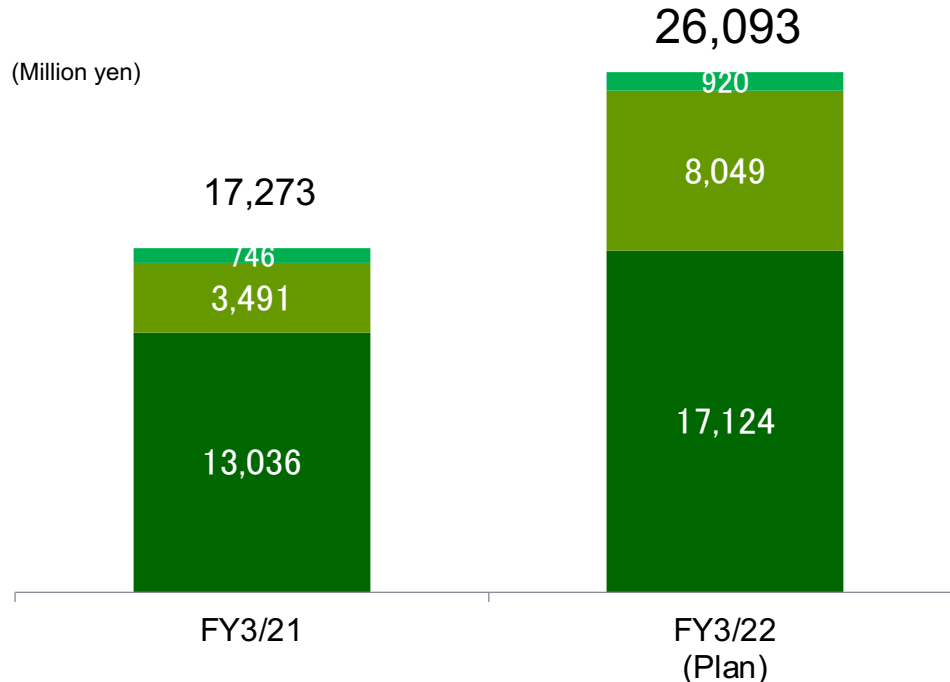

## Overview of this segment

Sales of thermoelectric modules and power semiconductor substrates are expected to increase

### [Thermo-electric module]

- Sales are expected to increase due to the strong demand for 5G communication devices and in the medical field, and expanding demand in the consumer electronics field.

### [Power semiconductor substrates]

- Demand for DCB substrates continues to grow, and sales are expected to increase.
- Demand for AMB substrates, for which a mass production system has been established, continues to grow, and sales are expected to expand rapidly.



**Ferrotec**  
Ferrotec Holdings Corporation



# Growth Investment and Financial Management

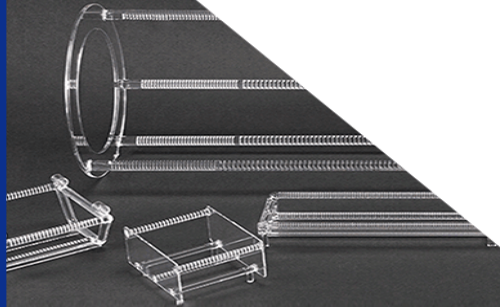

- As stated in the medium-term management plan, pursue business growth and profit growth and continue to invest for growth.
- Emphasize net income as a KPI and strengthen management of investment returns and ROIC.

<p><b>Total investment in medium-term plan:</b></p> <p><b>195 billion</b></p> <p>(FY3/22-FY3/24)</p>	<p><b>155 billion</b></p>	<p><b>Investment for short- and medium-term growth</b></p> <p>Aggressive investment to enhance production capacity to seize opportunities for market expansion, mainly in the semiconductor field and electronic devices</p>
	<p><b>140 billion</b></p>	<p><b>Investment for long-term growth</b></p> <p>1) Expansion of product range in the semiconductor field                  2) EV and new energy vehicle related                  3) Investment in <b>new core businesses</b></p> <p><small>*Variable depending on M&amp;A investment opportunities                  *ROIC will be considered with a target of 5% or more within 3 years</small></p>

## Financial Management

- **Continue to invest for growth to thoroughly pursue business and profit growth**

- **Focus on net income and convert to KPIs**
- **Strengthening investment-return and ROIC management**



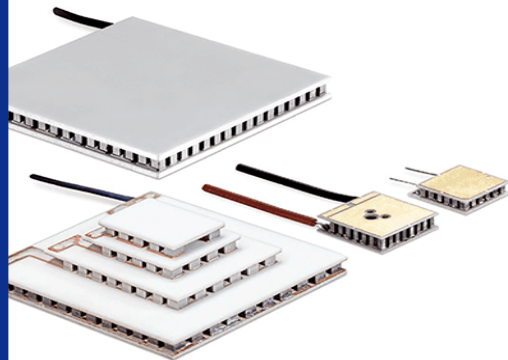

**Ferrotec**  
Ferrotec Holdings Corporation

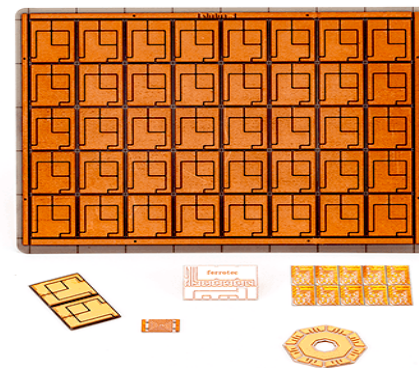

## Appendix

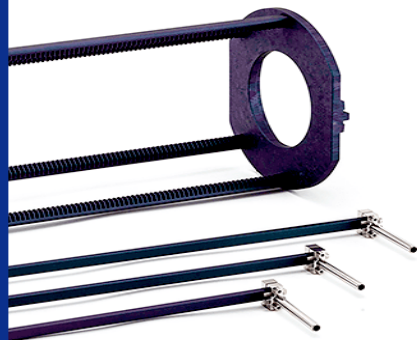

# Company Profile (as of September 30, 2021)



Corporate Name	Ferrotec Holdings Corporation
Date of Foundation	September 27, 1980
Address	5 <sup>th</sup> floor of Nihonbashi Plaza Building, 2-3-4 Nihonbashi, Chuo-ku, Tokyo Japan
Listed on	JASDAQ (Listed Code : 6890)
President	He Xian Han
Business Segment	Business management and R&D operations of group companies
Capital	18,546 million yen
Issued Stock	38,955,486 shares (including 93,852 shares of treasury stock)
Related Company	55 consolidated subsidiary 9 companies accounted for by the equity method
Employees	[Consolidated] 8,412 [Non-consolidated] 70

# Business Performance (FY3/22 1H Results vs. Plan)



(Million yen)	FY3/22 Q2 Plan		FY3/22 Q2 Results			
	Amount	Pct. of sales (%)	Amount	Pct. of sales (%)	Difference	Pct. change (%)
Semiconductor and other equipment-related	35,893	61.9	35,895	60.0	2	0.0
Vacuum feedthroughs	6,107	10.5	6,018	10.1	- 88	- 1.4
Quartz	10,295	17.7	10,132	16.9	- 163	- 1.6
Silicon parts	2,889	5.0	2,778	4.6	- 111	- 3.8
Ceramics	8,331	14.4	8,422	14.1	91	1.1
CVD-SiC	1,372	2.4	1,389	2.3	17	1.2
EB-Gun, LED	2,044	3.5	2,056	3.4	12	0.6
Wafer recycling	0	-	0	-	0	-
Wafer processing	42	0.1	43	0.1	1	2.4
Parts cleaning	4,432	7.6	4,483	7.5	50	1.1
Quartz crucibles	382	0.7	574	1.0	192	50.4
Electronic device	12,168	21.0	12,214	20.4	46	0.4
Thermo-electric module	8,417	14.5	8,424	14.1	7	0.1
Power semiconductors	3,315	5.7	3,349	5.6	34	1.0
Ferrofluid, others	435	0.8	440	0.7	5	1.1
Others	9,939	17.1	11,718	19.6	1,779	17.9
<b>Total</b>	<b>58,000</b>	<b>100.0</b>	<b>59,826</b>	<b>100.0</b>	<b>1,827</b>	<b>3.1</b>
Gross income	21,816	37.6	22,239	37.2	423	1.9
SG&A expenses	11,816	20.4	11,505	19.2	- 311	- 2.6
Operating income	10,000	17.2	10,733	17.9	733	7.3
Ordinary income	12,000	20.7	12,493	20.9	493	4.1
Net income	16,000	27.6	17,269	28.9	1,269	7.9

# Business Performance (FY3/22 1H Results vs. 2H Plan)



(Million yen)	FY3/22 1H Results		FY3/22 2H Plan			
	Amount	Pct. of sales (%)	Amount	Pct. of sales (%)	Difference	Pct. change (%)
Semiconductor and other equipment-related	35,895	60.0	40,484	62.1	4,589	12.8
Vacuum feedthroughs	6,018	10.1	7,200	11.0	1,182	19.6
Quartz	10,132	16.9	10,200	15.7	68	0.7
Silicon parts	2,778	4.6	4,500	6.9	1,722	62.0
Ceramics	8,422	14.1	9,150	14.0	728	8.6
CVD-SiC	1,389	2.3	1,560	2.4	171	12.3
EB-Gun, LED	2,056	3.4	2,010	3.1	- 46	- 2.2
Wafer recycling	0	-	4	0.0	4	-
Wafer processing	43	0.1	0	-	- 43	-
Parts cleaning	4,483	7.5	5,000	7.7	517	11.5
Quartz crucibles	574	1.0	860	1.3	286	49.7
Electronic device	12,214	20.4	13,880	21.3	1,666	13.6
Thermo-electric module	8,424	14.1	8,700	13.3	276	3.3
Power semiconductors	3,349	5.6	4,700	7.2	1,351	40.3
Ferrofluid, others	440	0.7	480	0.7	40	9.0
Others	11,718	19.6	10,810	16.6	- 908	- 7.7
<b>Total</b>	<b>59,826</b>	<b>100.0</b>	<b>65,174</b>	<b>100.0</b>	<b>5,348</b>	<b>8.9</b>
Gross income	22,239	37.2	24,327	37.3	2,088	9.4
SG&A expenses	11,505	19.2	12,560	19.3	1,055	9.2
Operating income	10,733	17.9	11,767	18.1	1,034	9.6
Ordinary income	12,493	20.9	11,007	16.9	- 1,486	- 11.9
Net income	17,269	28.9	6,232	9.6	- 11,037	- 63.9

# Business Performance (FY3/21 vs. FY3/22) Key Indicators



(Million yen)	FY3/21 Results		FY3/22 Plan			
	Amount	Pct. of sales (%)	Amount	Pct. of sales (%)	Difference	Pct. change (%)
Net sales	91,313	100.0	125,000	119.0	33,687	36.9
Gross income	30,783	33.7	46,566	44.3	15,783	51.3
SG&A expenses	21,142	23.2	24,065	22.9	2,923	13.8
Operating income	9,641	10.6	22,500	21.4	12,859	133.4
Ordinary income	8,228	9.0	23,500	22.4	15,272	185.6
Net income	8,281	9.1	23,500	22.4	15,219	183.8
Capital investment	14,297	-	32,000	-	-	-
Depreciation	9,155	-	8,000	-	-	-

- The forward-looking statements in this document are based on information available as of the date of publication of this document and assumptions concerning uncertain factors affecting future results.
- Actual results may differ materially from these forecasts due to various factors. Such factors include, but are not limited to, COVID-19 situation, international conditions, economic conditions, product supply and demand trends, raw material prices, market conditions, and exchange rates.
- The amount of capital investment for FY3/22 in this document is based on the budget for the current fiscal year and is not finalized. We undertake no obligation to update any information with respect to these matters
- For official forecasts, please refer to the disclosure of financial results based on the Tokyo Stock Exchange Regulations.

<Inquiries>  
IR Office: 03-3281-8186